

# SP 1800

Stationary concrete pump

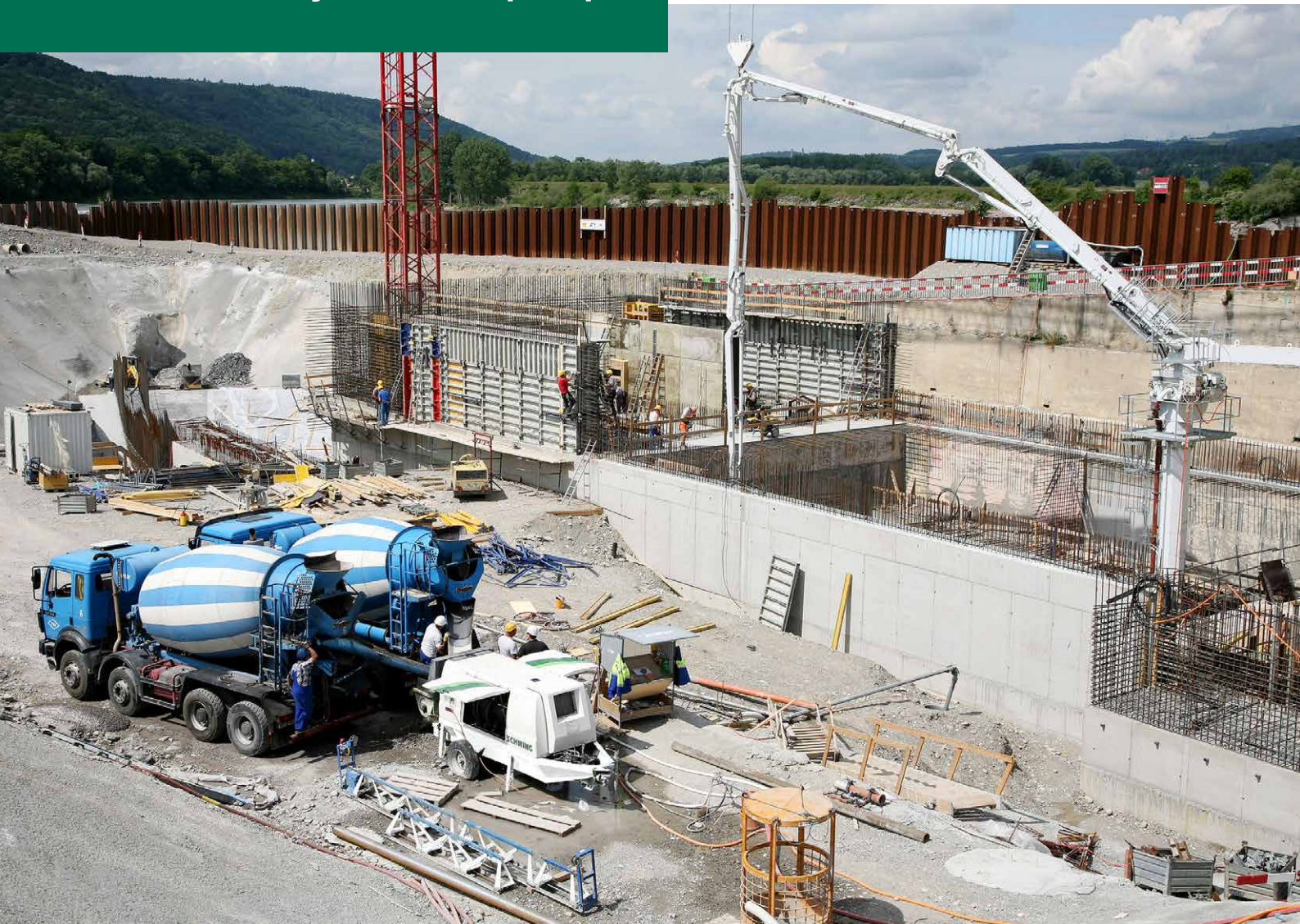

Concrete output	max.	95 m <sup>3</sup> /h
Pressure on concrete	max.	108 bar
Engine output		90 - 129 kW
Machine weight		5,100 - 5,400 kg
		11,250 - 11,900 lb



RECORD BREAKING ENGINEERING



# The SP 1800 from SCHWING

## Reliable versatility.

SP 1800 Stationary concrete pump

On construction sites around the world, the SP 1800 from SCHWING has been a central component of concrete logistics for decades. Proven technologies, such as the robust and easy-to-clean ROCK concrete valve and the SCHWING hydraulic components, guarantee high reliability, a strong output rate and low maintenance costs. In combination with the customer-oriented SCHWING service, the SP 1800 ensures more safety and efficiency in concrete pumping. The SP 1800 from SCHWING: manufactured in Germany. Operating worldwide.



SP 1800 E

**Cooling system**  
The heat development in the open hydraulic system of the SP 1800 is significantly lower than in closed systems. In connection with the large-volume hydraulic tank and the high-powered cooling system, the output rate of the SP 1800 thus remains constantly high even in the case of extreme external temperatures.



**Maintenance**  
The easy accessibility of the most important maintenance points of the SP 1800 reduces the time needed for daily maintenance to a minimum. The AdBlue/DEF container can be swiveled to the side for quick change of the pistons (SP 1800 D Stage V/Tier 4f). Instead of fixed changing intervals, the hydraulic oil is changed based on the results of the oil analysis to be carried out by the owner. This reduces the maintenance costs and protects the environment.

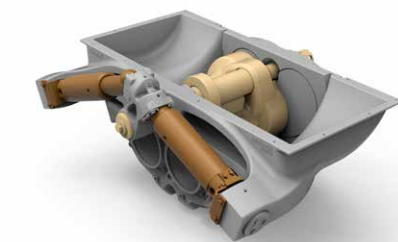

**ROCK concrete valve**  
In comparison with other concrete valves, the ROCK shows significantly lower wear due to its intelligent design. It is also quick to clean and is demonstrably easier to maintain. Advantage for the SP 1800: shorter servicing times, higher availability and lower maintenance costs.



SP 1800 D Stage V/Tier 4f



**Motors for every need**  
Due to its reliability and energy efficiency, the available drives of the SP 1800 ensure high productivity and low operating costs.

- Diesel engines**
- 115 kW power, Stage II/Tier 2 exhaust emission standard
  - 126 kW power, Stage IIIA/Tier 3 exhaust emission standard
  - 129 kW power, Stage V/Tier 4f exhaust emission standard, diesel particulate filter and SCR system

- Electric motors**
- 90 kW power, 50 Hz, efficiency class IE 3
  - 108 kW power, 60 Hz, efficiency class IE 3



The EcoClean procedure allows the placement of all concrete inside the pipeline for high-rise pumping. As such, material and disposal costs are reduced and the efficiency of the concrete pouring is increased. All stationary concrete pumps from SCHWING are prepared for the EcoClean procedure ex works.

**Operation**  
The clear operating structure and large-format colour display of the machine control allow for easy and intuitive operation of the SP 1800. Machine data, operating modes and selected settings can be retrieved quickly and various parameters can be changed. The integrated diagnosis system supports safe operation and alerts the operator to the maintenance intervals.



**Hydraulic system**  
Key hydraulic components of the SP 1800, such as the valve block and the differential cylinders, are developed and manufactured by SCHWING. Their generous dimensions and the open SCHWING hydraulic system guarantee a low-loss conversion of the engine power into the output rate. Result: the renowned high energy efficiency of SCHWING concrete pumps.



MADE IN GERMANY  
by SCHWING-Stetter



## SP 1800 Stationary concrete pump

# The ROCK

### Faster clean with less water.

Due to its straight design, in comparison to other concrete valves, the ROCK valve is easier and quicker to clean. It also provides a direct view into the delivery cylinder and of the pumping pistons. The pump kit can therefore be cleaned easily and conveniently within just two strokes. This saves water and reduces the time needed for cleaning.

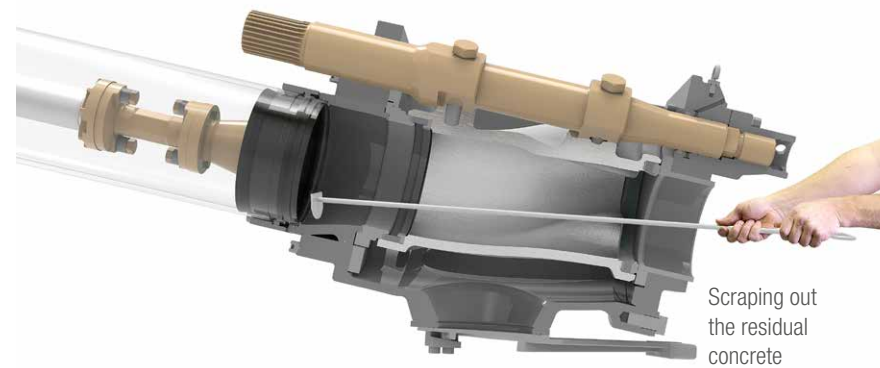

### Intelligent wear protection.

The wear in the concrete valve is particularly high as the concrete is fed into the outlet at high pressure. In order to minimize this wear, at the most heavily loaded point of the ROCK concrete does not rub on steel, but rather on concrete. This is because the intelligent design of the ROCK leads to the formation of a concrete triangle after each shift. Protected by this concrete layer, the ROCK has a significantly longer service life than other concrete valves. For noticeably more profit per m<sup>3</sup>.

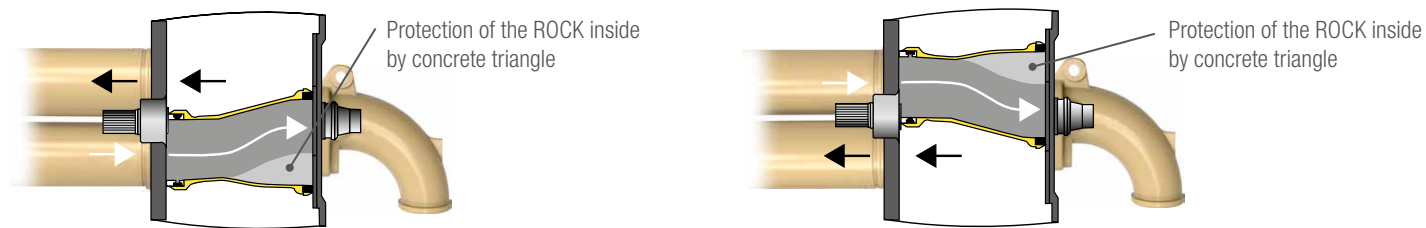

### Easy maintenance.

The ROCK valve not only has a significantly longer service life than other concrete valves, it is also easier to maintain. After removing the housing cover, the wear parts are easily accessible and can be replaced quickly and safely. Time-consuming adjustment work is not required after replacement. And the number of wearing parts at 15 with the ROCK valve is just half as high as with other concrete valves. The maintenance of the ROCK valve: simple, fast and safe.

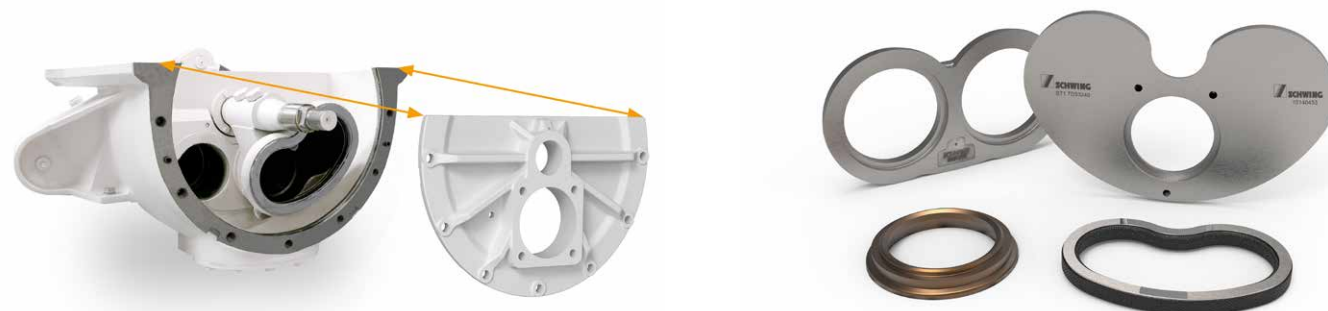

# Options

### Outlet options

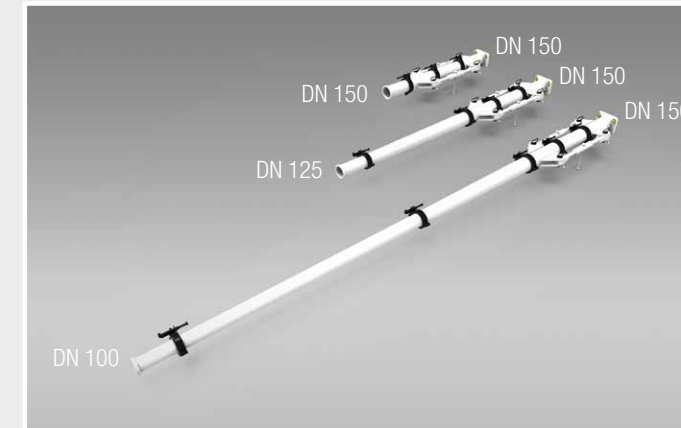

For the connection of the pipeline chosen for the project (DN 100, DN 125 or DN 150) to the outlet of the SP 1800 (DN 150), suitable output options are available.

### Remote controls



Cable remote control with 30 m cable

Radio remote control

### Hydraulic control unit



Components, such as a shut-off valve, can be easily operated by the SP 1800 (with up to 210 bar and up to 30 l/min) via the hydraulic control unit.

### Carbide wear parts

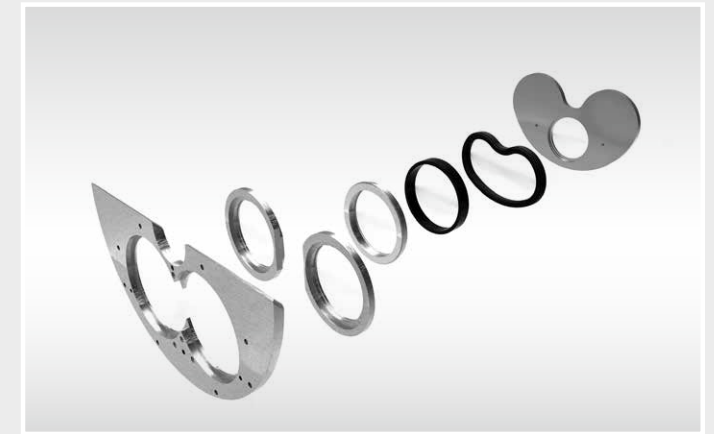

Due to the hardened surface, the carbide wear parts have a significantly longer service life than standard wear parts. As such, the maintenance effort and service costs are reduced, whilst the availability of the SP 1800 is increased.

### More options

Concrete vibrator on the grid

Water pump

### Standard equipment

Electrically driven ventilator

Four lashing eyes at the bottom

Four attachment points at the top at the bottom

Central greasing strip at the hopper

Emergency-off button at the hopper

Batteries with 170 Ah

Supporting leg

Pressure gauge for hydraulic pressure

# SP 1800 Stationary concrete pump

## Technical data

Designation		SP 1800 D Stage II/Tier 2	SP 1800 D Stage IIIA/Tier 3	SP 1800 D Stage V/Tier 4f	
Weight	kg / lb	5,400 / 11,900	5,300 / 11,700	5,400 / 11,900	
Length (L)	mm	5,950	5,950	5,950	
Height (H)	mm	2,550	2,570	2,330	
Width (B)	mm	1,950	1,950	1,950	
Width (C)	mm	1,532	1,532	1,530	
Height (G)	mm	1,880	1,880	1,910	
<b>Performance</b>		rod-sided	piston-sided	rod-sided	piston-sided
Pump kit		P1620		P1620	
Delivery cylinders	mm	200 x 1,600		200 x 1,600	
Concrete output max.	m <sup>3</sup> /hr	84	48	80	46
Pressure on concrete max.	bar	60	108	60	108
Stroke rate max.	1/min.	28	16	27	15
Concrete valve		L-ROCK		L-ROCK	
<b>Hydraulic system</b>					
Design		open system			
Hydraulic tank	l	400			
<b>Motors</b>					
Engine type		Diesel Deutz BF4M 1013EC	Diesel Deutz TCD2013 L04	Diesel CAT C4.4	
Engine power	KW	115	126	129	
Emission standard		Stage II/Tier 2	Stage IIIA/Tier 3	Stage V/Tier 4f	
Emission control system		-	-	DPF + SCR	
Fuel tank	l	250	250	250	

Designation		SP 1800 E (50 Hz)	SP 1800 E (60 Hz)		
Weight	kg	5,100 / 11,250	5,100 / 11,250		
Length (L)	mm	5,950	5,950		
Height (H)	mm	2,080	2,080		
Width (B)	mm	1,950	1,950		
Width (C)	mm	1,532	1,532		
Height (G)	mm	1,880	1,880		
<b>Performance</b>		rod-sided	piston-sided	rod-sided	piston-sided
Pump kit		P1620		P1620	
Delivery cylinders	mm	200 x 1,600		200 x 1,600	
Concrete output max.	m <sup>3</sup> /h	80	46	95	54
Pressure on concrete max.	bar	60	108	60	108
Stroke rate max.	1/min.	26	15	31	18
Concrete valve		L-ROCK		L-ROCK	
<b>Hydraulic system</b>					
Design		open system			
Hydraulic tank	l	400			
<b>Motors</b>					
Engine type		Electric motor		Electric motor	
Engine power	KW	90		108	
Frequenz	Hz	50		60	
Efficiency class		IE3		IE3	

Maximum concrete output and maximum pressure on concrete cannot be achieved simultaneously. DPF: Diesel particulate filter; SCR: selective catalytic reduction. Performance specifications are maximum theoretical values.

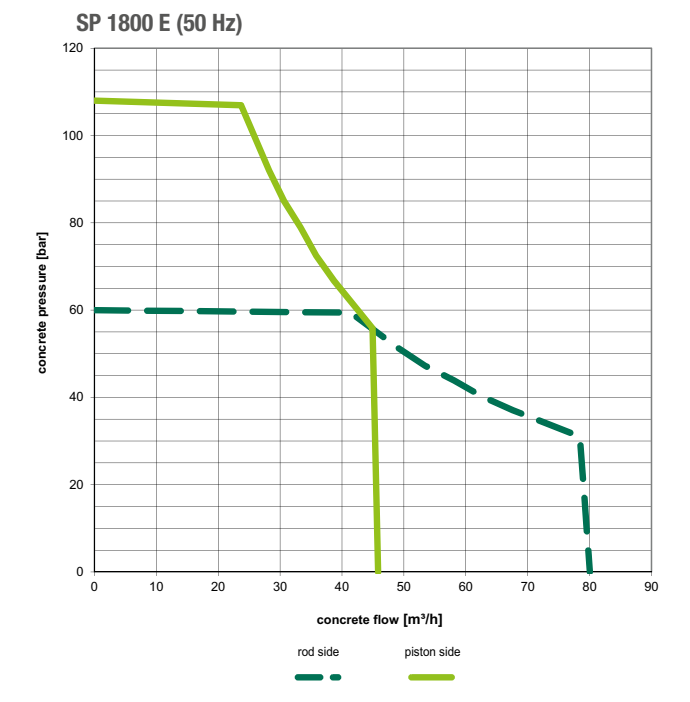
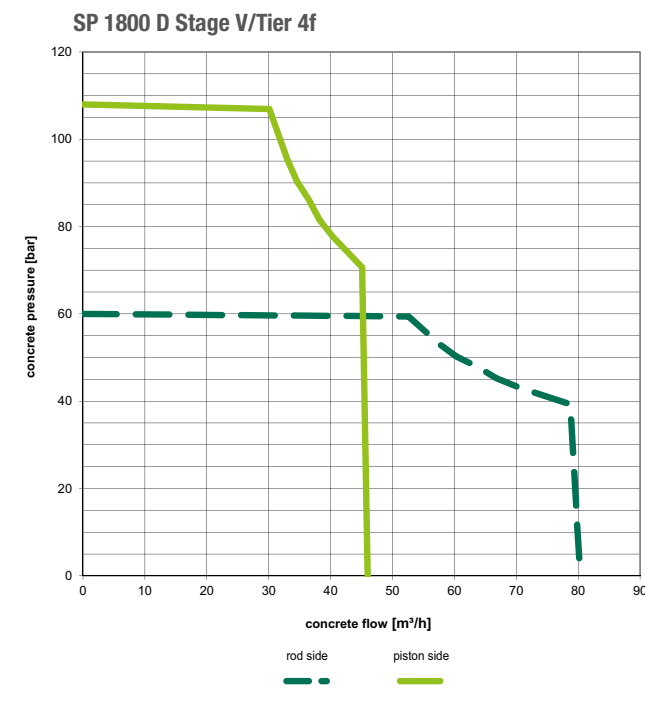
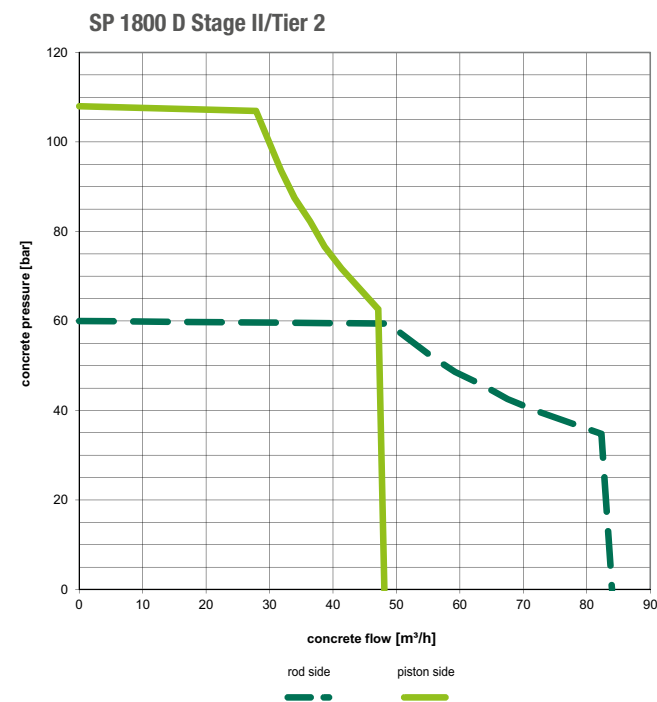
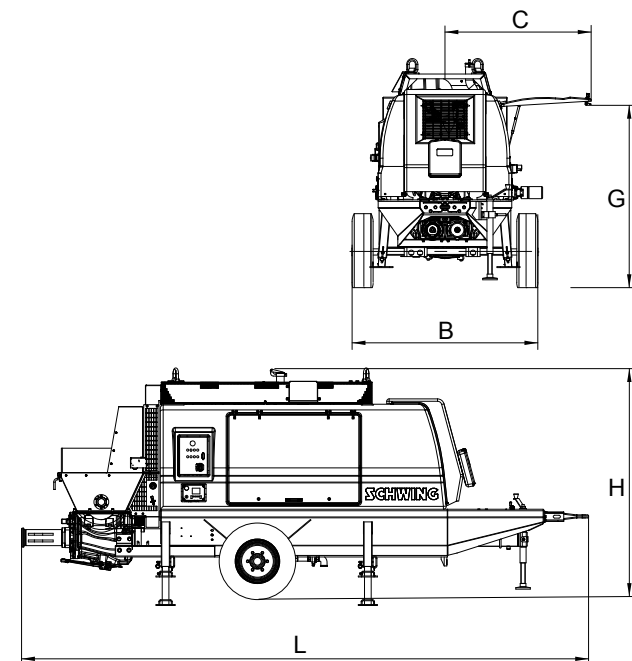





schwing-stetter



schwing.stetter



SCHWING stationary concrete pumps.  
Performance and safety at all levels.



**SCHWING**  
**Stetter**

SCHWING GmbH  
Heerstrasse 9-27 · 44653 Herne, Germany  
Phone +49 23 25 - 987-0 · Fax +49 23 25 - 72922  
www.schwing-stetter.com · info@schwing.de

Stetter GmbH  
Dr.-Karl-Lenz-Strasse 70 · 87700 Memmingen, Germany  
Phone +49 83 31 - 78-0 · Fax +49 83 31 - 78 275  
www.schwing-stetter.com · info@stetter.de

Subject to technical and dimensional modifications. Illustrations are non-binding. The exact standard specification, the scope of delivery and the technical data are detailed in the offer.